

# Show Garden Rules and Regulations 2024

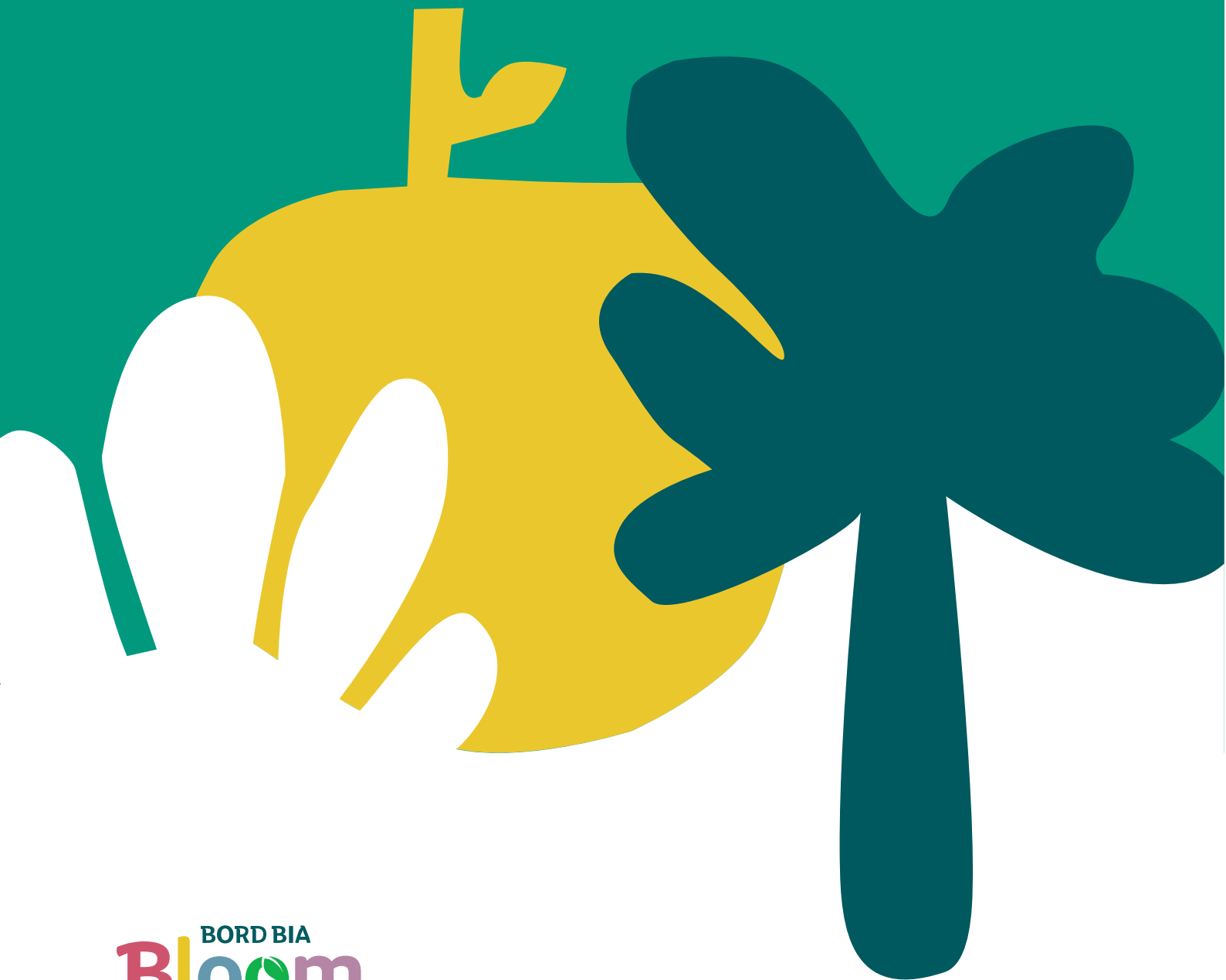

# Show Garden Rules & Regulations

**A detailed Garden Exhibitors Manual will be issued to all successful applicants in March 2024.**

## Important Notes

- Show gardens are categorised by size only and not by style. While this provides more scope to the designer to use his/her space without direction or restriction, it is incumbent on the designer to devise and adhere to clearly discernible design objectives against which the finished garden can be judged.
- While the *concept garden* category, provides a 'blank canvas' without aesthetic, horticultural or size restrictions they must be constructed in accordance with health & safety guidelines and most importantly, offer an enhanced outdoor sensory experience. It is envisaged that these gardens be used for conceptual, interactive or play-focused exhibits or spaces devoted to raising awareness of important social, economic, humanitarian or environmental issues, etc.
- Where the scheme favours the use of locally-sourced plants the designer should address this issue in the design process.
- Interest in Bord Bia Bloom is high and competition for space in some size categories will arise. Your application will benefit from a well-planned, legible and high quality presentation.
- The Garden Advisory Group (GAG) may reject applications or seek alterations to the design where there is a concern about insufficient budget, health & safety or proposed quality of finish. The GAG reserves the right to reject applications in order to protect the overall standards and reputation of the show, other exhibitors, designers and sponsors.
- The GAG reserves the right to withdraw a design from the show at any point up to and including the build-up period, should a major health & safety concern arise or where a major diversion from the brief is undertaken without approval from the GAG.
- Exhibitors and their contractors are asked to be respectful of other designers and contractors working on site and to cooperate with site supervisors and security personnel at all times. Where inappropriate behaviour is reported exhibitors may be asked to withdraw from the show.
- The provisional garden sizes available at Bord Bia Bloom 2024 are shown on the application form. Please note that these may be subject to minor change prior to site allocation

## 1. Application Requirements

Garden Applicants will be required to submit the following documents:

- A completed show garden **Application Form** (online form).  
\*It is essential that all required fields are completed.
- A completed Bord Bia Bloom show garden **Design Brief** (online form).  
An overview of your aims and objectives in creating the exhibit.
- One **Plan** drawn to scale (Minimum)  
Please clearly mark on the plan the scale of the drawing to the relevant paper size and include a north arrow where the brief makes reference to north, south etc. Please clearly annotate/label the drawing so all materials are identifiable.
- One **Elevation** (Minimum)  
Please clearly annotate/label the drawing so all materials, level changes and heights of boundaries and structures are clearly identifiable.
- One **Axonometric or Perspective/3D Sketch** (Minimum).
- A **Preliminary Planting List/Outline Planting Plan** (see section 5 of Design Brief).  
This is not necessary in a Concept Garden where plants will not be featured.

## 2. Boundary Treatment

Each show garden at Bord Bia Bloom must have 2 full public viewing sides (at least)

- The designer(s) will be responsible for the ground surfacing on (shared) viewing sides where permanent ground surfacing is not in place.
- Side walls and fences should be a maximum height of 2 metres. Changes will be permitted in some circumstances by the GAG and in consultation with exhibitors who are sharing boundaries. For small gardens side walls and fences should be no more than 1.8 metres high. There will be some flexibility in the height of front and side boundaries for small gardens located along the permanent walled site but all boundary treatments must be agreed with the GAG.
- Back walls and fences are not limited in height except for exhibits whose back walls or fences form a common boundary with other exhibits. In these cases, back walls and fences should be a maximum height of 2 metres.
- The height of all walls and fences should be clearly marked on the plan
- Walls and fences adjoining other exhibits must be finished to the same high standard on both sides unless agreed with neighbouring parties.
- Design of all exhibits **must include** the space required for boundary treatment in order to facilitate shared boundary points where necessary.
- It may be possible in some cases to accept an application for a show garden with 3 or 4 full public viewing sides, depending on site availability and approval by the GAG. However, designers should note that such sites may present restrictions in the location of commercial pagodas, etc.
- For Medium and Large Gardens, 0.5m lawn edging on viewing sides must be included within the chosen garden area (e.g. 8m x 10m exhibit plot = 7.5m x 9.5m garden + .5m edging on 2 sides). Lawn edging on viewing sides is not required within the small garden category.

- Boundary treatments for Concept Gardens will be assessed on an individual basis depending on location, design, health & safety requirements, etc.

### 3. Excavation

- All excavations greater than 0.5m **MUST** be declared on the application form. Where changes occur after the initial application process the SHOW GARDEN MANAGER must be notified.
- **Excavations greater than 300mm WILL NOT BE PERMITTED within the small gardens located along the Walled Garden. In addition, excavation work will NOT be permitted within 1m of the Walled Garden boundary wall. This is to protect the integrity of the Walled Garden structure.**

### 4. Buildings & Structures

Within reason, the height of buildings in garden exhibits is not limited. However, exhibitors must ensure that:

- The **height** of buildings, structures and trees in excess of 2.5 m is **clearly marked** on the drawings submitted.
- Buildings and structures exceeding 2 metres in height are positioned at least 1 metre away from perimeter walls or fences that form a common boundary with neighbouring exhibits. As a general guideline, the higher the building or structure, the further away it should be from a common boundary.

### 5. Existing/ Permanent Trees

- Exhibitors must ensure that construction work does not in any way harm any permanent trees on site.
- Exhibitors and contractors must ensure that excavations and heavy materials are kept as far away as possible from tree roots. The OPW may erect temporary fences where this issue arises.

### 6. Existing Walls and Building

- Exhibitors are not permitted to fix structures or plant supports to existing walls without prior permission from the Organisers. Please also refer to section 3. *Excavations* for working in proximity to the Walled Garden.

### 7. Screens, Posts and Ropes

- High quality posts and ropes must be erected along all garden frontages and boundaries open to public access. Posts and ropes must be supplied by exhibitors.
- Standard Ropes and Posts will be available for purchase via the signage contractor. An order form will be included in the Garden Exhibitor Manual (see section 21. below).

## 8. Conservation Measures

- Exhibitors should note that Bord Bia will support all measures which promote environmentally-friendly gardening, the use of timber from sustainable sources and the protection of wild and endangered species and habitats. Where Irish or international policies exist e.g. CITES these should be strictly adhered to. We reserve the right to demand the removal of plants and materials where the contravention of Irish or international legislation occurs. The use of mirrors and fish/animals will be closely monitored and may be restricted where serious concerns regarding animal welfare arise.
- Peat is not permitted for staging or mulching. Plants grown in peat based compost are permitted. In line with An Taisce sustainability policies, all peat sources must be licensed under the EPA IPPC Licensing procedures.

## 9. Judging

- Designers should note that the imaginative use of plant material, planting associations and overall design are all important aspects in the assessment of exhibits. The design and construction are also important factors in the assessment.
- Exhibitors should note that most show gardens at Bord Bia Bloom will be viewed from the perimeter(s) only and that the public are not permitted access except where some part or aspect of the garden has been designed in an interactive or sensory fashion. It is acceptable to design the garden in such a way that the public can walk through some part of the garden, provided that this can be done in a safe and controlled manner (see Section 11 – Criteria for Public Access). For the most part designers are encouraged to design the garden to be viewed from the outside only!
- Bord Bia Bloom show gardens should be designed primarily with the public in mind, but designers should take into account that judges will enter the garden for both stage 1 judging and final judging.
- Where major design, planting or construction changes are sought by the designer there will be an opportunity to meet with the organisers early in the building phase.
- **Please take careful note of the build access dates. All show gardens must be complete by nightfall on Sunday, 26th May 2024.**
- A Show Garden Managers Review will take place on Sunday, 28th May and designers should be very close to completion at this time. If it is deemed that a garden will not be completed by nightfall on Sunday, 26th May, the Show Garden Manager reserves the right to withdraw the garden from the judging process.
- Designers will have a brief opportunity (2 mins) to interpret/explain their design to the judging panel on Tuesday, 28th May but no machinery, vehicles or planting will be permitted on the site on Tuesday. Activities such as dead-heading, watering, cleaning and accessorising are permitted on Tuesday.
- Exhibitors must vacate their garden during final judging on Wednesday, 29th May.

Please note that exhibits will be judged over two days, in accordance with the following schedule and rules:

- **Sun, 26.05.24 11:00 – 16:00**  
Show Garden Manager's Garden Review – this will comprise general assessment of each garden's build progression and readiness for judging. All building, construction and planting must be complete by nightfall on Sunday.
- **Mon, 27.05.24 All day**  
Finishing touches and ready for photography – Only cleaning and accessorising of garden is permitted (permission for other works to be agreed in advance with the show garden manager)
- **Tue, 28.05.24 All day**  
Judging with opportunity for 2 minute Presentation to GAG. Designers should note that section *17 Construction and Breakdown* for permitted activities during stage 1 judging.
- **Wed, 29.05.24 07:00** Gardens Vacated by contractors and build team.  
**08:00 – 15:00** Stage 2/Final Judging - Restricted access  
**10.00 – 18:00** Media Preview - Designer(s) present
- **Use of Locally-Sourced Plants** - While there is no desire to limit the palette of plants used or in any way to influence design styles or themes, the GAG will pay close attention to the choice and origin of plants used for both economic and environmental reasons. Designers are encouraged to use plants that are sourced as locally as is feasible. Where this is successfully addressed the GAG will award additional marks during the judging process. Bord Bia Bloom, Bord Bia and garden designers share a responsibility to educate the public on the best choice of plants for use in our climate.
- The main criteria used by the garden judges are listed below, together with the maximum points they may award for each element of the exhibit. While verbal 'feedback' may be provided post event, if requested, a written breakdown of **points awarded will not be made available**.

## Judging Criteria

- I. **Meeting the Brief**
  - a. Realisation of brief and feasibility/practicability as per client/location /use identified in the brief  
Maximum Points Awarded = 20
- II. **Overall Impression/Design**
  - a. Impact
  - b. Originality
  - c. Balance and Scale  
Maximum Points Awarded = 30
- III. **Construction**
  - a. Quality
  - b. Finish
  - c. Special Features  
Maximum Points Awarded = 20
- IV. **Planting**
  - a. Design, Colour and Texture
  - b. Association and Relevance
  - c. Quality and Finish
  - d. Use of locally-sourced plant material  
Maximum Points Awarded = 30

*Please note that an unfinished garden will not be judged and therefore it cannot be awarded a medal. In order to facilitate maximum creativity these judging criteria will not apply in full to exhibits in the Concept Garden category*

## 10. Design Brief

- As part of the judging of each garden, the GAG/Judges refer to your Design Brief as the basis of their deliberations. Please complete the Design Brief questionnaire and return it with your entry.
- While exhibitors will be encouraged to update their brief as the need arises it will not be possible to submit alterations after **First Week in May 2024 (Date TBC)**.
- It is very important that the design brief accurately reflects the design intention and actual construction of the garden at the show incorporating any amendments made to the design.
- If no revised version is received, the original design brief submitted at the time of application will be used by the judges in assessing and judging the garden.

## 11. Bord Bia Bloom Awards

**Gold, Silver-Gilt, Silver and Bronze** medal awards will be available.

- If an exhibit is considered to be below Bronze standard, no award will be made. A letter informing designers that no award has been made will be placed on the garden in this instance.
- The judges reserve the right to amend or change a garden category from/to a Concept Garden should this facilitate a higher mark/medal.
- Awards will be announced on the morning of Thursday, 1<sup>st</sup> June and placed on the gardens.
- Small, Medium, Large and Concept Show Garden exhibitors will also be eligible for a 'best in category' award and a number of other special awards such as the 'Best Planting', 'Designers Favourite' and 'The People's Choice'.
- Concept Gardens must be finished to the same high standard as other garden categories.
- Awards to Concept Gardens are regarded as highly as awards to other garden categories.

## 12. Gardens - Criteria for Public Access

- Although it is acknowledged that public access to certain gardens can enhance the appreciation of your design concept and allow a greater sensory experience for visitors, it should be noted that allowing the public to access your garden can raise a number of issues which should be seriously considered before applying for public access permission:
  - Public Access can be problematic from a Health & Safety point of view requiring all H&S provisions listed below to be addressed at the outset of the design process.

- Show gardens must remain in 'Show Condition' for the entirety of the 5 day show. Damage to the interior of your garden is inevitable where public access is permitted, potentially creating additional maintenance work during the show. It is the responsibility of the designer to take steps to maintain the garden's appearance throughout the event.
- Allowing the public to access your garden will create an obstructed view of the garden for all other visitors on external walkways as will queues forming along the exterior of your garden (see stipulations below regarding queue management). Therefore, provision of the best possible exposure for your garden to all visitors to the show should be considered before public access permission is sought.
- Special permission is required by any designer wishing to allow public access to the garden during the show and the organisers must be informed in advance of the arrangements which will be put in place to manage public access.
- Pathways through garden exhibits which are intended for use by the public must be a minimum of **1.5m wide** at all points to allow for comfortable access through the space for visitors and wheelchair users.
- All pathways through gardens must be one-way routes with the entrance only and exit only access points clearly marked.
- The management of queuing is the responsibility of the garden designer and ample personnel must be provided to direct queues both on the interior and the exterior of the garden.
- Where queues form to access a garden, they must be aligned along the front of that garden only. At no point should a queue form in front of another garden or in any way obscure the view to another garden.
- The organisers reserve the right to close a garden to public access where it is deemed that the garden access route is unsafe or unsuitable in any way for public access or that queuing is causing crowd control issues within the show garden area.
- Exhibitors must comply at once with any requirement imposed on the organisers by the Gardaí, Fire or other authorities. [Gas to IS 820 2019, Fire Blankets BS EN 1869 2019]. See also Bord Bia Bloom Garden Manual and Garden Events Ltd Rules & Regulations.



- The following critical dimensions for Wheelchair users may be useful in considering ease of access and viewing points from within the garden.

Critical dimensions of wheelchair user	
Eye level of wheelchair user	1245mm
Seated height of wheelchair user	1300 - 1385mm
Reach over high table	600mm
Width of wheelchair user allowing for elbows	900mm
Turning circle - manual wheelchair user	1500mm
Turning circle - outdoor wheelchair user	2400mm
Turning circle – electric pavement wheelchair user	4350mm

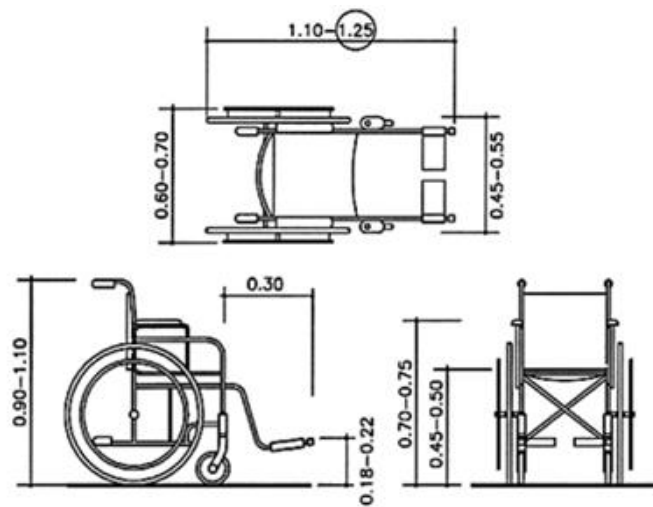

### 13. Website / Catalogue Entry

- A website / catalogue entry will be required for each exhibit at the show.
- You will be required to submit the following information in February - March 2024
  - Summary of the garden concept, design elements and purpose (Max 150 words)
  - 1 Image of the garden (jpeg max 300dpi)
  - 1 head & shoulders image of the designer (jpeg max 300dpi) - if no image is supplied, information supplied in 2007-2022 (where applicable) will be used.
  - Designer Biography – if no biography is supplied, information supplied in 2007-2022 (where applicable) will be used.
- The website / catalogue entry must include a description of the exhibit including an explanation of any special or unique features. The entry should make it clear who has promoted the garden and why, e.g. to promote a product, a corporate profile or a garden designer. The description could include helpful information describing the purpose of the garden and its assumed location.
- Designers seeking guidance on the style and format of the website / catalogue entry should refer to the 2023 garden entries on the Bord Bia Bloom website ([www.BordBiaBloom.com](http://www.BordBiaBloom.com)) and previous show guides (2019 – 2022).
- It is obligatory for each show garden exhibitor to submit a website / catalogue entry before the deadline specified.

### 14. Signage

- For each garden the organisers will commission 1 No. sign.
- **Garden Information Sign** - The sign will comprise of two elements:-
  - The exhibitor's name, the title of the garden, site number and main sponsor's name/logo (as listed on the Website and in the Show Catalogue). **These details will be extracted from the Garden Sign Form and passed to the signage contractor by the organiser.**
  - Name of the main contractor and up to three product suppliers. The exhibitor can have a degree of freedom in terms of colour, print style, etc. Exhibitors should supply the signage contractor with the requested wording for this section of the sign and any special requirements relating to colour, print style, etc.
- **No other signs may appear on the garden.**
- The signs will be positioned on the main frontage of the garden by the organiser or signage contractor.

### 15. Sampling

- Samples may not be distributed from gardens. However, the organisers will provide space adjacent to the gardens suitable for this purpose. Each garden will be offered a standard 3m x 3m marquee which will be located adjacent to the show garden.

- No retail activity will be permitted from pagodas. These areas are to be used for the dissemination of information or samples only.
- All promotional activity from pagoda units must be conducted exclusively within the interior of the unit and promotional staff are not permitted to conduct activities on the adjacent walkways.
- Food sampling by food company sponsors from pagoda sites may be permitted with special permission from the organisers. Exhibitors who are granted permission for food sampling must adhere to the following maximum size sample quantities:
  - Food sample – bite size/canapé size only.
  - Wine sample - 30ml (Circa 1 oz)
  - Beer sample - 50ml (Circa 1¾ oz)
  - Spirit sample - 5ml (Circa ¼ oz)
  - Non-Alcoholic Drinks (Juices, Smoothies...etc) - 100ml (Circa 3½ oz)
  - Tea/Coffee/Hot Drinks - 150ml (Circa 5 oz)
- Sampling in excess of these quantities is prohibited unless agreed in advance and in writing with the organisers. An additional fee for Product Placement may be applied.
- For product categories where the Bord Bia Q Mark is applicable sampling will only be permitted for brands with the Q Mark and exhibitors are encouraged to support locally produced product.

## 16. Bord Bia Bloom Funding

- Bord Bia Bloom may offer support from €50 per sq metre for show gardens and concept gardens, based on GAG approval and the applicant's ability to secure match funding through sponsorship, product placement, etc.
- Only designs which are approved by the GAG will be assessed for funding approval. There will be a cap placed on the number of gardens in each category receiving funding and it will not be possible to offer support to all gardens.
- Designers who are offered Bord Bia Bloom funding will not be restricted in acknowledging sponsors, product suppliers, partners in garden signage, leaflets, catalogues, etc.
- Under some circumstances where sufficient commercial sponsorship from a 3rd party can be raised to fund a garden, this commercial sponsorship should replace Bord Bia Bloom funding, particularly where Bord Bia Bloom organisers have been instrumental in raising such 3rd party support.
- A separate Garden Funding Application form must be requested by designers who wish to apply for this funding.
- Applicants for Bord Bia Bloom Garden Funding will be informed of the level of funding available at the end of the GAG application review process.
- All designers in receipt of Bord Bia Bloom Garden Funding will be required to complete a Bord Bia Creditor Set-up Form, which will be supplied with your acceptance.
- Funding will be released on a tiered basis as follows:
  - 50%      Within 10 days of the commencement of construction of the garden on-site
  - 40%      Within 10 working days of the completion of the garden

- 10% Within 10 working days of complete clearance of the site following the show
- This funding will be issued under the terms and conditions outlined in the application literature.
- Accepted applicants will be sent a contract which will outline the agreement with Bord Bia Bloom and the designer's commitment to the building of the garden with the assistance of Bord Bia Bloom pooled sponsorship funding. The signed contract should be returned to the organisers as set out in the letter of acceptance.
- The signed contract should be accompanied by an pro forma invoice for the full amount of the Bord Bia Bloom funding plus VAT (where applicable). Invoices should be addressed to Bord Bia, c/o Garden Events Ltd, 8/9 Sandyford Office Park, Sandyford, Dublin 18.
- A Tax Clearance Certificate will also be required from designers who have been in receipt of monies from Bord Bia totalling more than €10,000 in any 12 month period. Successful applicants will be informed if a tax clearance certificate is required. Please note that under no circumstances will be payments over €10,000 in any 12 month period be paid to a designer without the presentation of a valid Tax Clearance Certificate.

## 17. Construction and Breakdown

- Construction of gardens will be on a phased basis between 25 days and 14 days in advance of the show opening and in relation to garden sizes. Exact dates will be confirmed in the Garden Exhibitor's Manual (see *section 18* below).
- All major construction work (including excavation, foundations, buildings, conservatories, walling and paving) must be completed in the first two weeks of the build.
- Where removal of excavated soil is required the volume of soil must be communicated in advance to the organisers
- All gardens **must be completed** by nightfall on **Sunday, 28th May**.
- **Tuesday, 28<sup>th</sup> May** (Stage 1 judging). Activities such as dead-heading, cleaning, accessorising will be permitted but **no planting will be allowed** (unless agreement with the Show Garden Manager, Kerrie Gardiner in advance). The use of machinery or vehicles will not be permitted.
- **Wednesday, 29<sup>th</sup> May** (Stage 2 judging). Scheduled Media Preview **with Restricted Access**. Designers Present and available for interviews and photographs. Designers will be asked to vacate their garden for judging.
- Exhibitors will be advised of the breakdown schedule in the Garden Exhibitor Manual. All gardens must be vacated and grounds restored to their original condition (ready for seeding by other) by 17:00hrs on Wednesday, 12<sup>th</sup> June 2024. **A charge of €100 per day will be levied to designers with un-cleared sites / uncollected materials after Wednesday, 12<sup>th</sup> June 2024.** A **Site Clearance Certificate** will be in place where a member of the Bord Bia Bloom team will sign off on each garden site. This form will be required for the final release of funding/deposit as appropriate.
- Once you have made your application and a site has been allocated for your garden, those not in receipt of show funding **will be required to pay a deposit of €1000 (large/medium garden or equivalent size concept garden) or €500 (small garden or equivalent size concept garden).** This is fully refundable and will be re-paid to you provided that you build your garden at the show. Refunds will not be returned to garden applicants who cancel after March 2024 or to exhibitors who fail to clear their site following the show.

## 18. Construction Regulations

Where substantial excavations, structures, (e.g. pavilions, walls, pools etc.) are proposed the garden construction (build) may come under the **Construction Regulations**. Please review this link for more information;

<http://www.hsa.ie/eng/Legislation/Acts/Safety Health and Welfare at Work/Safety Health and Welfare at Work General Application Amendment Regulations 2012/Construction Regulations SI 504 2006.pdf>

## 19. Use of Fibreglass

- Fibreglass may only be used under strict supervision and only if pre-agreed with the organisers.

## 20. Animal Welfare

- The use of mirrors and fish/animals will be closely monitored and may be restricted where serious concerns regarding animal welfare arise.
- In situations where it is proposed to include animals in a garden exhibit, an **animal welfare statement** will be required.

## 21. Bord Bia Bloom 2024 Show Garden Exhibitor Manual

- The 2024 Show Garden Exhibitor Manual and order forms and pricing information for tickets and services (water, electricity, etc.) will be sent to confirmed exhibitors in March 2024.

## 22. Design and Craft Council of Ireland

- Any designers looking for the commissioning or installation of work by crafts people associated with the Design and Craft Council of Ireland should email their request to [info@ccoi.ie](mailto:info@ccoi.ie) Designers are urged to make contact with the Design and Craft Council of Ireland early in the garden planning process in order to facilitate appropriate lead times for development of crafts pieces.

## 23. Items not Allowed

These items **may not be exhibited** or used on gardens:-

- Balloons are NOT permitted in the Phoenix Park.
- Branded bunting, flags or other merchandise / accessories which may detract from the garden.
- Any other item deemed by the Organisers to have no direct or demonstrable relevance to the show garden, horticulture or gardening.
- Materials emitting a foul or unpleasant odour (including spray paints, aerosols and fibres) may not be used in the staging of any exhibit.

## 24. Items Requiring Special Permission

These items which may only be exhibited or used in displays with the special permission of the Show Garden Manager:-

- Artificial plant material.
- Fruit or flowers (cut flowers) artificially attached to a plant or incorporated into garden.
- Dormant bulbs and corms.
- Placement of clothing within the garden including branded t-shirts, coats, shirts and sweatshirts (except gardening gloves, gardening aprons, gardening boots, gardening shoes and straw hats).
- Banners.
- Food and drink.
- Live animals of any kind.
- Music/sound effects.

For information on Bord Bia Bloom please contact:

**Kerrie Gardiner**

Show Gardens Manager | Bord Bia Bloom

+353 (0)86 130 4170

[kerrie.gardiner@bordbiabloom.com](mailto:kerrie.gardiner@bordbiabloom.com)

[www.BordBiaBloom.com](http://www.BordBiaBloom.com)

